



Flostar S

Designed to meet the advanced needs of water utilities in large revenue collection applications

Engineered for reliability and built upon 20 years of industry-leading design, Itron's Flostar S is the best choice for drinking water metering in commercial and industrial applications.

FEATURES AND BENEFITS

- » Low flow accuracy
- » Peak flow capacity
- » Highly engineered materials

Wide Measuring Range

Flostar S is a single jet meter available in sizes from DN 65 to 150.

Its metrological performances far exceed ISO/IEC Class C standards.

Its low flow accuracy range combined with significant peak flow capacity ensure complete and efficient measurement whatever the faced flow-rates.

Reliability

Flostar S features a direct magnetic transmission between the turbine and the register without any intermediate gearing in the metered water.

This results in a very robust and reliable design able to withstand most types of potable water environments.

Ease of read in the toughest humid environments (ie: flooded pits) is secured by hermetically sealed IP68 register (copper can/mineral glass envelope).

Simple an effective

Simple but highly engineered materials and design enable a very long durability and the best performances for water metering.

Endurance & Peak Flow Resistance

Performance over time is a key requirement for efficient billing. Flostar S features a patented turbine ball pivoting enhancing endurance at low flow-rates. Hydrodynamic balance and turbine design bring resistance at high and peak flows.

- » Robust ductile cast iron body
- » Hermetically sealed register (coppercan/mineral glass envelope)
- » Patented ball pivot
- » Patented turbine levitation



Flostar S DN 150



Cyble EverBlu Enhanced fitted on Flostar S

WORKING PRINCIPLE

Flostar S is a single jet meter. The water jet is canalized by an injector before hitting the turbine. The single jet tapered injector straightens the flow profile. Its large bore area prevents meter overspeed by clogging.

The high precision design of the inlet **1** allows Flostar S to meet best accuracy without the need for any bypass or calibration vane adjustment system. The turbine movement is directly transmitted to the extra dry register through a magnetic coupling **2** without the need for any intermediate gearing in the metered water.

This allows Flostar S to conserve its initial accuracy over time, under the most demanding service conditions of potable water networks.

High quality material for the turbine bearings and patented ball pivot **3** design allows detection of leakages initially and over time regardless of the flow profiles. The hermetically sealed copper can/mineral glass envelope of the IP68 register **4** is safeguarding the read and integrity of the indicator in the toughest environments (flooded pits, mechanical tampering attempts, ...).

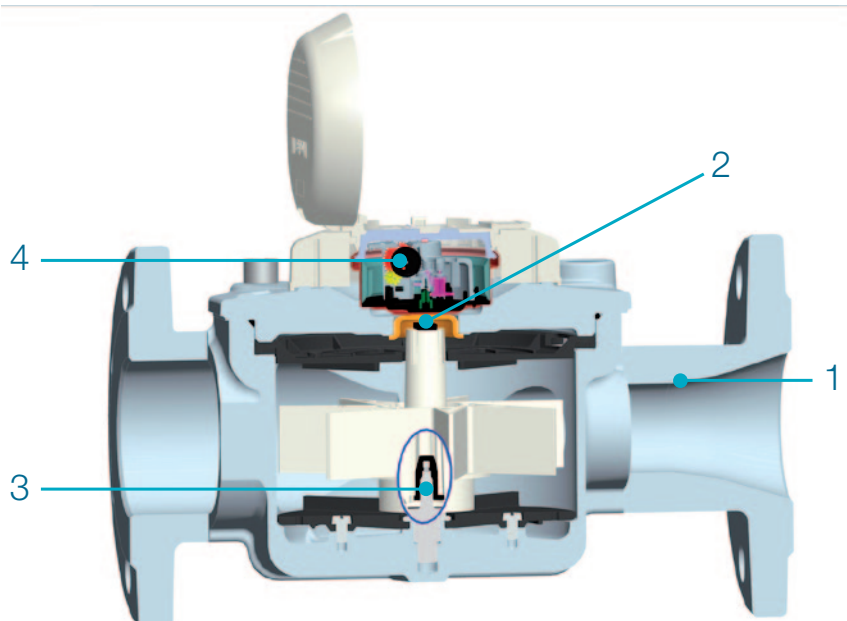

Flostar S DN100 cut section

COMMUNICATION : READY FOR SMART METERING

Flostar S is supplied pre-equipped with Cyble Target

Allows communication and remote reading through:

- » Pulse output (Cyble Sensor)
- » M-Bus protocol (Cyble M-Bus)
- » Radio frequency wireless link (Cyble AnyQuest or EverBlu)

These Cyble modules allow the Flostar S meter to be connected with various associated systems like our supervision system WaterMind (see specific leaflet). They are particularly adapted to commercial and industrial applications where a need for frequent meter monitoring is expressed especially in hard-to-read locations.

Key Advantages of Cyble Technology

- » No need for additional investment on the meter to implement remote reading
- » Itron standardized meter interface, irrespective of meter technology and widely spread on Itron water meters range
- » Reliability brought by electronic switch (no wear or bouncing)
- » Reverse flow management
- » Principle proven on the field with a 25 years experience
- » Pre-equipment being immune to magnetic tampering

METROLOGICAL CHARACTERISTICS

MID / EN 14154 / ISO 4064:2005 / OIML R49 Approval Values

MID Approval Certificate N° LNE-23700						
Nominal diameter (DN)	mm	65	80	100	150	
Minimal flowrate (Q1)	l/h	≥ 127*	≥ 200*	≥ 317*	≥ 400*	
Transition flowrate (Q2)	l/h	≥ 203	≥ 320	≥ 508	≥ 640	
Permanent flow rate (Q3)	m³/h	40	63	100	160	
Overload flowrate (Q4)	m³/h	50	78.75	125	200	
Dynamic (Q3/Q1)		≤ 315	≤ 315	≤ 315	≤ 400	
Standard Ratio (Q3/Q1)		315	315	315	315	
Q2/Q1			1.6			
Accuracy class			2			
Temperature class	°C		T50		T30	
Maximum Admissible Pressure	bar		16		20	
Orientation			Horizontal		Horizontal	
Indicating range	m³		999999		9999999	
Verification scale interval	L		0.5		2	
Climatic influence class			+5°C to +55°C			

* respectively with dynamics Q3/Q1



Performance Values

Nominal diameter (DN)	mm	65	80	100	150
	inches	2" 1/2	3"	4"	6"
Starting flow*	l/h	35	50	70	90
Accuracy ± 2% from*	l/h	120	180	280	300
Accuracy ± 5% from*	l/h	100	120	170	200
Admissible peak flow (2 hrs. max.)**	m³/h	60	90	135	260
Max. temperature for short period	°C		60		
Max. admissible pressure	bar		20		
Cyble HF pulse weight	L		10		100

* Average values - ** Without impact on accuracy performances.

High Performance Coating

Flostar S bodies are protected with tough and highly corrosion resistant coating for longer service life even under harsh installation conditions.



TYPICAL ACCURACY CURVE, FLOSTAR S Q3 = 63 M³/H

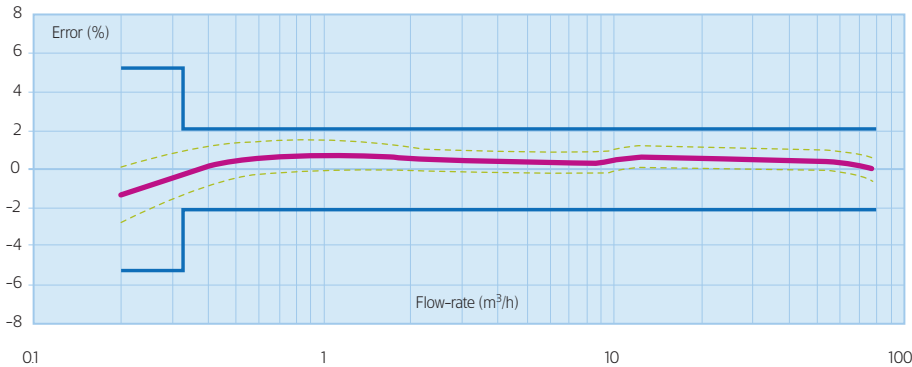

HEAD LOSS

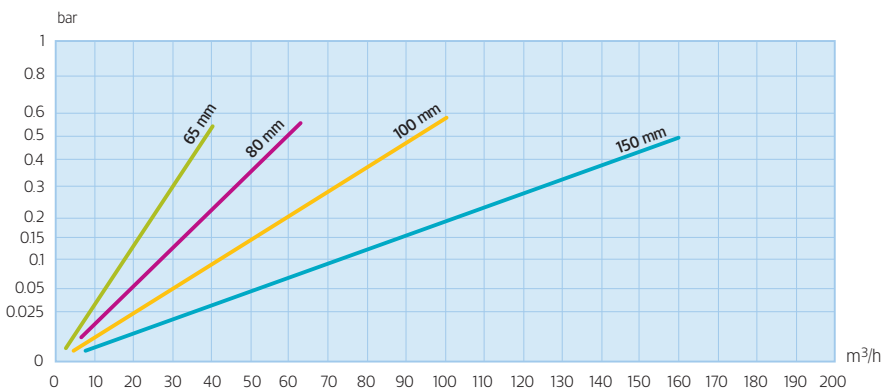

DIMENSIONS

Nominal diameter (DN)	mm	65	80	100	150
Meter connections		Fixed flanges ISO PN10/16			
A (length)	ISO mm	300	350	350	450*
B	mm	180	200	184	240
C	mm	120	150	166	210
D	mm	92	100	110	144
E (open)	mm	218	223	238	261
E (closed)	mm	129	135	148	173
F	mm	92	100	110	144
G	mm	118	166	188	235
Weight	Kg	17	20	32	63

* Additional sleeve DN 150 length 50 mm available.

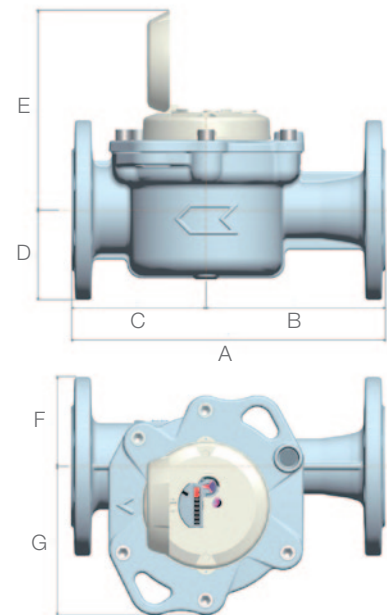

INSTALLATION REQUIREMENTS

- » Flostar S should be installed in the horizontal position with totalizer facing up for optimum performances.
- » Installation of a strainer upstream of the meter is recommended to protect the hydraulics against debris that might result from accidents on the network, piping corrosion, ... (see Itron strainer leaflet)
- » Flostar S is not sensitive to flow disturbers (sensitivity class U0D0)



Our company is the world's leading provider of smart metering, data collection and utility software systems, with over 8,000 utilities worldwide relying on our technology to optimize the delivery and use of energy and water.

To realize your smarter energy and water future, start here: www.itron.com

For more information, contact your local sales representative or agency:

ITRON WATER METERING

9, rue Ampère
71031 Mâcon cedex
France

Phone: +33 3 85 29 39 00

Fax: +33 3 85 29 38 58